

**KUNKLE SAFETY AND RELIEF PRODUCTS**  
 MODELS 300 AND 600

ASME Section I Steam, and ASME Section VIII Air/Gas/Steam



Model 300 and 600

**Model descriptions**

**Model 300:** Cast steel, exposed spring, full nozzle with SS trim. ANSI 300# inlet flange and 150# outlet flange.

**Model 600:** Cast steel, exposed spring, full nozzle with SS trim. ANSI 600# inlet flange and 150# outlet flange.

**Features**

- Heavy duty construction of high quality cast steel with Stainless Steel (SS) full-nozzle trim for optimum performance.
- Bolted yoke design for easy maintenance.
- Steel yoke incorporates a cover-shield for guiding surfaces and provides for fully exposed spring.
- Seats lapped to optical flatness for tight shutoff.
- Dual control rings offer easy adjustability for precision opening with minimum pre-open or simmer and exact blowdown control.
- All adjustments are factory sealed to help prevent tampering or disassembly.
- Each Kunkle valve is tested and inspected for pressure setting and leakage.

**Technical data**
**Pressure and Temperature Limits**

Temperature °F	Maximum Set Pressure	
	300 Series	600 Series
-20 to 100	740 psig	1000 psig
200	680 psig	1000 psig
300	655 psig	1000 psig
400	635 psig	1000 psig
500	605 psig	1000 psig
600	570 psig	1000 psig
650	550 psig	1000 psig
700	530 psig	1000 psig
750	505 psig	1000 psig
800	410 psig	825 psig

**Notes:**

1. Model 300, Q orifice Maximum set pressure 600 psig.
2. Model 600, N orifice Maximum set pressure 750 psig @ 800°F.
3. Model 600, P orifice Maximum set pressure 750 psig @ 800°F.
4. Model 600, Q orifice Maximum set pressure 600 psig @ 800°F.
5. Maximum pressure subject to temperature/pressure limits.
6. Minimum set pressure 15 psig.

**Applications**

- Steam boilers and generators.
- Pressure reducing stations.
- Air/gas compressors - reciprocating or rotary.
- Pressure vessels - including tanks, receivers, intercoolers, oil/gas separators, lines.

Code:



# KUNKLE SAFETY AND RELIEF PRODUCTS

## MODELS 300 AND 600

### Parts and Materials

No.	Part Name	Materials
1	Nozzle <sup>1</sup>	SS
2	Body	Steel, SA216 Gr. WCB
3	Warn Ring	SS, A743 Gr. CF8
4	Disc Holder <sup>2</sup>	SS
5	Disc Retainer	SS, A313-316
6	Control Ring Pin Assembly	SS, A582-416
7	Control Ring	SS, A743 Gr. CF8
8	Warn Ring Pin Assembly	SS, A582-416
9	Guide	SS, A743 Gr. CF8
10	Yoke	Steel, SA216 Gr. WCB
11	Bolt <sup>3</sup>	Steel, SAE Gr. 5
12	Lever	Ductile Iron, A536
13	Stem	SS, A582-416
14	Spring	4
15	Spring Step	Steel, Commercial Grade with coating
16	Compression Screw	SS, A582-416
17	Lever Pin	CS, Commercial
18	Cotter Pin	Steel, Commercial
19	Locknut	SS, A582-416 or Steel A108-1215 Zinc Plated
20	Lift Cam	Ductile Iron, A536
21	Cap	Ductile Iron, A536
22	Lift Nut	CS, Commercial
23	Lift Disc Nut	SS, A582-303
24	Lift Pin	CS, Commercial
25	Cap Screw	CS, Commercial
26	Spring Pin	SS, Commercial
27	Stem Retainer	SS, A582-416
28	Retainer Locknut	SS, A582-416
29	Shield	SS, A167-316 Sheet
30	Disc	SS, A479-304

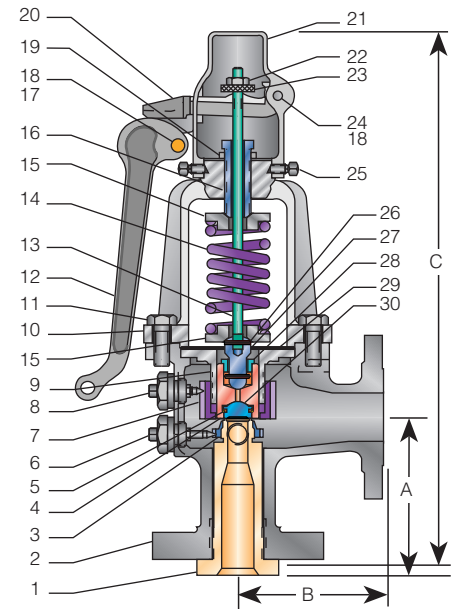

Models 300 and 600

#### Notes:

1. Specified materials: SA479 TY 304 on "F" through "M" orifices and SA351 Gr. CF8 on "N" through "Q" orifices.
2. Specified materials: A564-630 condition A1100 on "F" through "K" orifices and A479-304 on "L" through "Q" orifices.
3. 4 bolts required for "F" through "P" orifices and 6 bolts required for "Q" orifices.
4. Specified materials: CS with anti-corrosion coating for standard service. Alloy steel for high-temperature service.

### Specifications

Model Number	Orifice <sup>1</sup>	Connections		Orifice Area in <sup>2</sup>	Valve Dimensions			Approximate Weight (lb)
		ANSI Standard Inlet <sup>2</sup>	Outlet <sup>3</sup>		A	B	C	
300LFF / 600NFF	F	1 1/4"	1 1/2"	0.307	4 7/8	4 1/2	16 1/2	37
300LGF / 600NGF	G	1 1/4"	1 1/2"	0.503	4 7/8	4 1/2	16 1/2	39
300LHG / 600NHG	H	1 1/2"	2 1/2"	0.785	5 3/8	5 1/2	18 1/4	60
300LJG / 600NJG	J	1 1/2"	2 1/2"	1.287	5 3/8	5 1/2	20 7/8	75
300LKH / 600NKH	K	2"	3"	1.839	5 3/4	6	21 1/2	95
300LLJ / 600NLJ	L	2 1/2"	4"	2.853	6 5/8	6 5/8	26 1/2	133
300LMK / 600NMK	M	3"	4"	3.597	6 3/4	6 5/8	27 1/8	159
300LNM / 600NNM	N	4"	6"	4.340	8	7 1/4	33 5/8	230
300LPM / 600NPM	P	4"	6"	6.380	8	7 1/4	33 5/8	226
300LQP / 600NQP	Q	6"	8"	11.045	9 3/4	9 1/4	39 3/4	400

Dimensions are for reference only.

#### Notes:

1. Maximum set pressure:  
F to M orifice steam or air service - 1000 psig  
N and P orifice - 750 psig  
Q orifice - 600 psig
2. Inlet flanges are ANSI B16.5 300# (Model 300 only), 600# (Model 600 only).
3. Outlet flanges are ANSI B16.5-150#.

# KUNKLE SAFETY AND RELIEF PRODUCTS

MODELS 300 AND 600

## ASME Section I Steam - Capacities (U.S., lb/hr) - Flow Coefficient = 0.878

Set Pressure (psig)	Orifice Area, in <sup>2</sup>									
	F (0.307)	G (0.503)	H (0.785)	J (1.287)	K (1.839)	L (2.853)	M (3.597)	N (4.340)	P (6.380)	Q (11.045)
15	440	721	1125	1845	2636	4089	5156	6221	9145	15832
20	509	835	1303	2136	3052	4734	5969	7202	10587	18329
25	579	948	1480	2427	3468	5379	6782	8183	12030	20826
30	648	1062	1658	2718	3883	6024	7596	9164	13472	23323
35	718	1176	1835	3009	4299	6670	8409	10146	14915	25820
40	787	1290	2013	3300	4715	7315	9222	11127	16357	28317
45	856	1403	2190	3591	5131	7960	10035	12108	17799	30814
50	926	1517	2368	3882	5546	8605	10848	13089	19242	33311
55	995	1631	2545	4173	5962	9250	11662	14071	20684	35809
60	1065	1744	2722	4464	6378	9895	12475	15052	22127	38306
65	1134	1858	2900	4754	6794	10540	13288	16033	23569	40803
70	1205	1974	3081	5051	7218	11198	14118	17034	25040	43350
75	1276	2091	3264	5351	7646	11862	14955	18044	26526	45922
80	1348	2208	3447	5651	8074	12526	15793	19055	28012	48494
85	1419	2326	3629	5950	8503	13191	16631	20066	29498	51066
90	1491	2443	3812	6250	8931	13855	17468	21076	30983	53638
95	1562	2560	3995	6550	9359	14519	18306	22087	32469	56210
100	1634	2677	4178	6849	9787	15184	19143	23098	33955	58782
125	1991	3263	5092	8348	11928	18506	23332	28151	41383	71642
150	2349	3848	6006	9846	14070	21827	27520	33204	48812	84502
175	2706	4434	6920	11345	16211	25149	31708	38257	56240	97362
200	3064	5020	7834	12843	18352	28471	35896	43311	63669	110222
225	3421	5605	8748	14342	20493	31793	40084	48364	71097	123082
250	3779	6191	9662	15840	22635	35115	44272	53417	78525	135943
275	4136	6777	10576	17339	24776	38437	48460	58470	85954	148803
300	4493	7362	11490	18837	26917	41759	52648	63523	93382	161663
325	4851	7948	12404	20336	29058	45080	56836	68577	100811	174523
350	5208	8534	13318	21834	31199	48402	61025	73630	108239	187383
375	5566	9119	14232	23333	33341	51724	65213	78683	115668	200243
400	5923	9705	15146	24831	35482	55046	69401	83736	123096	213103
425	6281	10291	16060	26330	37623	58368	73589	88790	130525	225963
450	6638	10876	16974	27829	39764	61690	77777	93843	137953	238823
475	6996	11462	17888	29327	41905	65012	81965	98896	145382	251684
500	7353	12048	18802	30826	44047	68333	86153	103949	152810	264544
525	7711	12633	19716	32324	46188	71655	90341	109002	160239	277404
550	8068	13219	20630	33823	48329	74977	94530	114056	167667	290264
575	8425	13805	21544	35321	50470	78299	98718	119109	175096	303124
600	8783	14390	22458	36820	52612	81621	102906	124162	182524	315984
625	9140	14976	23372	38318	54753	84943	107094	129215	189953	—
650	9498	15562	24286	39817	56894	88265	111282	134269	197381	—
675	9855	16147	25200	41315	59035	91586	115470	139322	204810	—
700	10213	16733	26114	42814	61176	94908	119658	144375	212238	—
725	10570	17319	27028	44312	63318	98230	123846	149428	219666	—
750	10928	17904	27942	45811	65459	101552	128035	154482	227095	—
775	11285	18490	28856	47309	67600	104874	132223	—	—	—
800	11643	19076	29770	48808	69741	108196	136411	—	—	—
825	12000	19661	30684	50306	71883	111518	140599	—	—	—
850	12357	20247	31598	51805	74024	114839	144787	—	—	—
875	12715	20833	32512	53303	76165	118161	148975	—	—	—
900	13072	21418	33426	54802	78306	121483	153163	—	—	—
925	13430	22004	34340	56300	80447	124805	157351	—	—	—
950	13787	22589	35254	57799	82589	128127	161540	—	—	—
975	14145	23175	36168	59297	84730	131449	165728	—	—	—
1000	14502	23761	37082	60796	86871	134771	169916	—	—	—

# KUNKLE SAFETY AND RELIEF PRODUCTS

MODELS 300 AND 600

## ASME Section VIII Steam - Capacities (U.S., lb/hr) - Flow Coefficient = 0.878

Set Pressure (psig)	Orifice Area, in <sup>2</sup>									
	F (0.307)	G (0.503)	H (0.785)	J (1.287)	K (1.839)	L (2.853)	M (3.597)	N (4.340)	P (6.380)	Q (11.045)
15	454	744	1161	1903	2719	4218	5319	6417	9433	16331
20	523	857	1338	2194	3135	4863	6132	7398	10876	18828
25	593	971	1516	2485	3551	5508	6945	8380	12318	21325
30	662	1085	1693	2776	3966	6153	7758	9361	13761	23822
35	739	1210	1888	3096	4424	6863	8653	10440	15347	26569
40	815	1335	2084	3416	4881	7573	9547	11519	16934	29316
45	891	1460	2279	3736	5338	8282	10442	12599	18521	32063
50	968	1585	2474	4056	5796	8992	11336	13678	20107	34810
55	1044	1710	2669	4376	6253	9701	12231	14757	21694	37557
60	1120	1835	2864	4696	6711	10411	13125	15837	23281	40303
65	1197	1961	3060	5016	7168	11120	14020	16916	24867	43050
70	1273	2086	3255	5336	7625	11830	14915	17995	26454	45797
75	1349	2211	3450	5656	8083	12539	15809	19075	28041	48544
80	1426	2336	3645	5977	8540	13249	16704	20154	29627	51291
85	1502	2461	3841	6297	8997	13958	17598	21233	31214	54037
90	1578	2586	4036	6617	9455	14668	18493	22313	32801	56784
95	1655	2711	4231	6937	9912	15377	19387	23392	34387	59531
100	1731	2836	4426	7257	10369	16087	20282	24471	35974	62278
125	2113	3462	5402	8857	12656	19634	24755	29868	43907	76012
150	2495	4087	6379	10458	14943	23182	29227	35265	51841	89746
175	2876	4713	7355	12058	17230	26730	33700	40661	59774	103480
200	3258	5338	8331	13658	19516	30277	38173	46058	67707	117214
225	3640	5964	9307	15259	21803	33825	42646	51455	75641	130948
250	4022	6589	10283	16859	24090	37372	47118	56851	83574	144682
275	4403	7214	11259	18459	26376	40920	51591	62248	91507	158417
300	4785	7840	12235	20060	28663	44468	56064	67645	99441	172151
325	5167	8465	13211	21660	30950	48015	60537	73041	107374	185885
350	5548	9091	14187	23260	33237	51563	65009	78438	115307	199619
375	5930	9716	15164	24861	35523	55111	69482	83834	123241	213353
400	6312	10342	16140	26461	37810	58658	73955	89231	131174	227087
425	6694	10967	17116	28061	40097	62206	78428	94628	139107	240821
450	7075	11593	18092	29662	42384	65753	82900	100024	147041	254555
475	7457	12218	19068	31262	44670	69301	87373	105421	154974	268289
500	7839	12844	20044	32862	46957	72849	91846	110818	162907	282023
525	8221	13469	21020	34463	49244	76396	96319	116214	170840	295758
550	8602	14095	21996	36063	51531	79944	100791	121611	178774	309492
575	8984	14720	22973	37663	53817	83491	105264	127008	186707	323226
600	9366	15345	23949	39264	56104	87039	109737	132404	194640	336960
625	9748	15971	24925	40864	58391	90587	114210	137801	202574	—
650	10129	16596	25901	42464	60678	94134	118682	143198	210507	—
675	10511	17222	26877	44065	62964	97682	123155	148594	218440	—
700	10893	17847	27853	45665	65251	101230	127628	153991	226374	—
725	11275	18473	28829	47265	67538	104777	132101	159388	234307	—
750	11656	19098	29805	48866	69824	108325	136573	164784	242240	—
775	12038	19724	30782	50466	72111	111872	141046	—	—	—
800	12420	20349	31758	52066	74398	115420	145519	—	—	—
825	12802	20975	32734	53667	76685	118968	149992	—	—	—
850	13183	21600	33710	55267	78971	122515	154464	—	—	—
875	13565	22226	34686	56867	81258	126063	158937	—	—	—
900	13947	22851	35662	58468	83545	129610	163410	—	—	—
925	14329	23477	36638	60068	85832	133158	167883	—	—	—
950	14710	24102	37614	61668	88118	136706	172355	—	—	—
975	15092	24727	38591	63269	90405	140253	176828	—	—	—
1000	15474	25353	39567	64869	92692	143801	181301	—	—	—

# KUNKLE SAFETY AND RELIEF PRODUCTS

MODELS 300 AND 600

## ASME Section VIII Air/Gas - Capacities (U.S., SCFM) - Flow Coefficient = 0.878

Set Pressure (psig)	Orifice Area, in <sup>2</sup>									
	F (0.307)	G (0.503)	H (0.785)	J (1.287)	K (1.839)	L (2.853)	M (3.597)	N (4.34)	P (6.38)	Q (11.045)
15	162	265	413	677	968	1502	1893	2284	3358	5813
20	186	305	476	781	1116	1731	2183	2633	3871	6702
25	211	346	540	885	1264	1961	2472	2983	4385	7591
30	236	386	603	988	1412	2190	2762	3332	4898	8480
35	263	431	672	1102	1575	2443	3080	3716	5463	9457
40	290	475	742	1216	1737	2695	3398	4100	6028	10435
45	317	520	811	1330	1900	2948	3717	4485	6592	11413
50	344	564	881	1444	2063	3201	4035	4869	7157	12390
55	372	609	950	1558	2226	3453	4354	5253	7722	13368
60	399	653	1020	1672	2389	3706	4672	5637	8287	14346
65	426	698	1089	1786	2551	3958	4990	6021	8851	15324
70	453	742	1159	1900	2714	4211	5309	6405	9416	16301
75	480	787	1228	2013	2877	4463	5627	6790	9981	17279
80	508	831	1298	2127	3040	4716	5946	7174	10546	18257
85	535	876	1367	2241	3203	4968	6264	7558	11111	19234
90	562	921	1437	2355	3365	5221	6582	7942	11675	20212
95	589	965	1506	2469	3528	5474	6901	8326	12240	21190
100	616	1010	1576	2583	3691	5726	7219	8711	12805	22168
125	752	1232	1923	3153	4505	6989	8811	10631	15629	27056
150	888	1455	2270	3722	5319	8252	10403	12552	18453	31945
175	1024	1677	2618	4292	6133	9514	11995	14473	21276	36833
200	1160	1900	2965	4862	6947	10777	13588	16394	24100	41722
225	1296	2123	3313	5431	7761	12040	15180	18315	26924	46611
250	1431	2345	3660	6001	8575	13303	16772	20236	29748	51499
275	1567	2568	4008	6571	9389	14565	18364	22157	32572	56388
300	1703	2791	4355	7140	10203	15828	19956	24078	35396	61276
325	1839	3013	4703	7710	11017	17091	21548	25999	38219	66165
350	1975	3236	5050	8279	11831	18354	23140	27920	41043	71054
375	2111	3459	5397	8849	12644	19616	24732	29841	43867	75942
400	2247	3681	5745	9419	13458	20879	26324	31762	46691	80831
425	2383	3904	6092	9988	14272	22142	27916	33682	49515	85719
450	2519	4126	6440	10558	15086	23405	29508	35603	52339	90608
475	2654	4349	6787	11128	15900	24667	31100	37524	55162	95497
500	2790	4572	7135	11697	16714	25930	32692	39445	57986	100385
525	2926	4794	7482	12267	17528	27193	34284	41366	60810	105274
550	3062	5017	7830	12837	18342	28456	35876	43287	63634	110162
575	3198	5240	8177	13406	19156	29718	37468	45208	66458	115051
600	3334	5462	8524	13976	19970	30981	39060	47129	69282	119940
625	3470	5685	8872	14545	20784	32244	40653	49050	72105	—
650	3606	5907	9219	15115	21598	33507	42245	50971	74929	—
675	3741	6130	9567	15685	22412	34770	43837	52892	77753	—
700	3877	6353	9914	16254	23226	36032	45429	54812	80577	—
725	4013	6575	10262	16824	24040	37295	47021	56733	83401	—
750	4149	6798	10609	17394	24854	38558	48613	58654	86225	—
775	4285	7021	10957	17963	25668	39821	50205	—	—	—
800	4421	7243	11304	18533	26482	41083	51797	—	—	—
825	4557	7466	11652	19103	27296	42346	53389	—	—	—
850	4693	7689	11999	19672	28110	43609	54981	—	—	—
875	4828	7911	12346	20242	28924	44872	56573	—	—	—
900	4964	8134	12694	20811	29738	46134	58165	—	—	—
925	5100	8356	13041	21381	30551	47397	59757	—	—	—
950	5236	8579	13389	21951	31365	48660	61349	—	—	—
975	5372	8802	13736	22520	32179	49923	62941	—	—	—
1000	5508	9024	14084	23090	32993	51185	64533	—	—	—

# KUNKLE SAFETY AND RELIEF PRODUCTS

MODELS 300 AND 600

## Model Number/Order Guide

Model Number Position	1	2	3	4	5	6	7	8	9	10	11	12	13	14	15
-----------------------	---	---	---	---	---	---	---	---	---	----	----	----	----	----	----

Example	3	0	0	L	L	J	0	1	—	A	S	0	0	2	0
---------	---	---	---	---	---	---	---	---	---	---	---	---	---	---	---

### Model

300  
600

### Connection Type

L - 300# Flange x 150# Flange  
(Model 300)  
N - 600# Flange x 150# Flange  
(Model 600)

### Orifice

F	L
G	M
H	N
J	P
K	Q

### Inlet Size

F - 1 1/4"  
G - 1 1/2"  
H - 2"  
J - 2 1/2"  
K - 3"  
M - 4"  
P - 6"

### Variation

01 - Catalog Standard

### Design Revision

Indicates non-interchangeable revision. Dash (-) if original design.

### Valve Service

A - Steam ASME Section I  
K - Air ASME Section VIII  
L - Steam ASME Section VIII

### Spring Material

S - Steel (to 750°F)  
F - Alloy Steel High Temperature (to 800°F)

### Set Pressure

15 psig (0015) to 740 psig (0740) - Model 300  
15 psig (0015) to 1000 psig (1000) - Model 600



VALVES & CONTROLS

5500 WAYZATA BLVD # 800, MINNEAPOLIS, MN 55416 WWW.PENTAIR.COM/VALVES  
KUNKLE FACILITY PHONE: 1-828-669-3700 • WWW.KUNKLEVALVE.COM

All Pentair trademarks and logos are owned by Pentair, Inc. All other brand or product names are trademarks or registered marks of their respective owners. Because we are continuously improving our products and services, Pentair reserves the right to change specifications without prior notice. Pentair is an equal opportunity employer.